

# Incremental encoders

## Solid shaft with EURO flange B10

### 25...5000 pulses per revolution



RAD ELECTRIC Int.  
www.radelectric.co

OG 9



OG 9

#### Features

- Encoder with solid shaft  $\varnothing 11$  mm
- Optical sensing method
- EURO flange B10
- Output stage HTL with power linedriver
- Output stage TTL with regulator UB 9...26 VDC
- Operating temperature up to +100 °C

#### Technical data - electrical ratings

Voltage supply	9...30 VDC 5 VDC $\pm 5$ % 9...26 VDC
Consumption w/o load	$\leq 100$ mA
Pulses per revolution	25...5000
Phase shift	$90^\circ \pm 20^\circ$
Duty cycle	40...60 %
Reference signal	Zero pulse, width $90^\circ$
Sensing method	Optical
Output frequency	$\leq 120$ kHz $\leq 300$ kHz (on request)
Output signals	K1, K2, K0 + inverted
Output stages	HTL-P (power linedriver) TTL/RS422
Interference immunity	EN 61000-6-2
Emitted interference	EN 61000-6-3
Approvals	CE, UL approval / E256710

#### Technical data - mechanical design

Size (flange)	$\varnothing 115$ mm
Shaft type	$\varnothing 11$ mm solid shaft
Admitted shaft load	$\leq 250$ N axial $\leq 350$ N radial
Flange	EURO flange B10
Protection DIN EN 60529	IP 55
Operating speed	$\leq 12000$ rpm (mechanical)
Operating torque typ.	1 Ncm
Rotor moment of inertia	280 gcm <sup>2</sup>
Materials	Housing: aluminium die-cast Shaft: stainless steel
Operating temperature	-30...+100 °C -25...+100 °C (>3072 pulses per revolution)
Resistance	IEC 60068-2-6 Vibration 10 g, 10-2000 Hz IEC 60068-2-27 Shock 100 g, 6 ms
Corrosion protection	IEC 60068-2-52 Salt mist for ambient conditions C4 according to ISO 12944-2
Explosion protection	II 3 G Ex nA IIC T4 Gc (gas) II 3 D Ex tc IIIB T135°C Dc (dust)
Connection	Terminal box
Weight approx.	980 g



# Incremental encoders

## Solid shaft with EURO flange B10

### 25...5000 pulses per revolution

OG 9

#### Part number

#### Incremental encoder

OG9 **DN**

Voltage supply / signals  
 I 9...30 VDC / output stage HTL with inverted signals  
 TTL 5 VDC / output stage TTL with inverted signals  
 R 9...26 VDC (<95 pulses), 9...30 VDC (≥95 pulses) / output stage TTL with inverted signals (for output signals DN)

Pulse number - see table

Output signals

DN K1, K2, K0

#### Accessories

#### Connectors and cables

HEK 8 Sensor cable for encoders

#### Mounting accessories

K 35 Spring washer coupling for solid shaft ø6...12 mm

K 50 Spring washer coupling for solid shaft ø11...16 mm

K 60 Spring washer coupling for solid shaft ø11...22 mm

#### Diagnostic accessories

11075858 Analyzer for encoders HENQ 1100

#### Pulse number

25	256	720	2048	5000
120	360	1000	2500	
128	500	1024	3072	
180	512	1250	4096	

Other pulse numbers on request.

# Incremental encoders

## Solid shaft with EURO flange B10

### 25...5000 pulses per revolution



RAD ELECTRIC Int.  
www.radelectric.com

## OG 9

### Output signals

At positive rotating direction

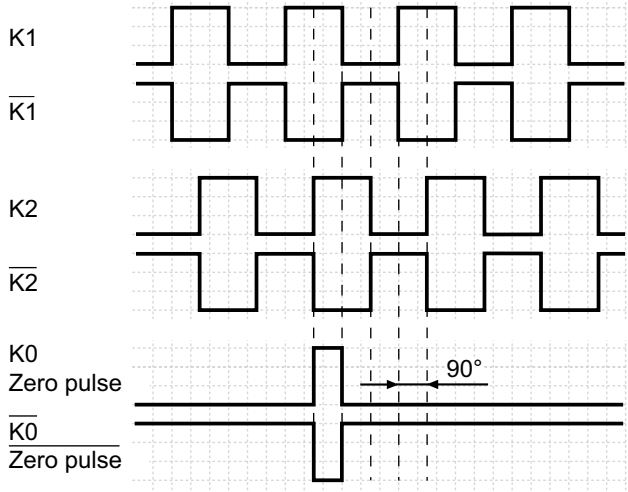

### Terminal significance

+UB	Voltage supply (for the device)
⊥; ↓; GND; 0 V	Ground (for the signals)
⊕; ↗	Earth ground (housing)
K1; A; A+	Output signal channel 1
K1-bar; A-bar; A-	Output signal channel 1 inverted
K2; B; B+	Output signal channel 2 (offset by 90° to channel 1)
K2-bar; B-bar; B-	Output signal channel 2 (offset by 90° to channel 1) inverted
K0; C; R; R+	Zero pulse (reference signal)
K0-bar; C-bar; R-bar; R-	Zero pulse (reference signal) inverted
dnu	Do not use

### Terminal assignment

View A - Connecting terminal terminal box

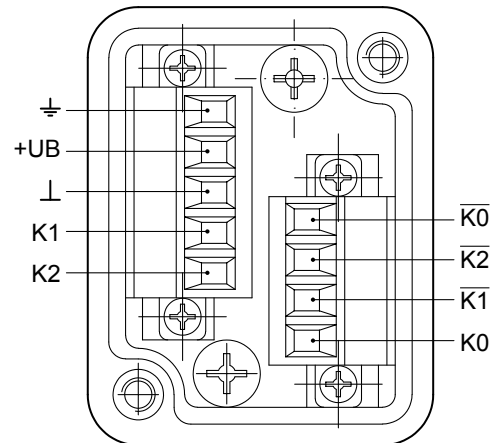



**Dimensions**

