

# Incremental encoders

Through hollow shaft  $\varnothing 40$  to  $\varnothing 65$  mm  
1000...2500 pulses per revolution



RAD ELECTRIC Int.  
www.radelectric.co

## ITD 70 A 4 Y 9

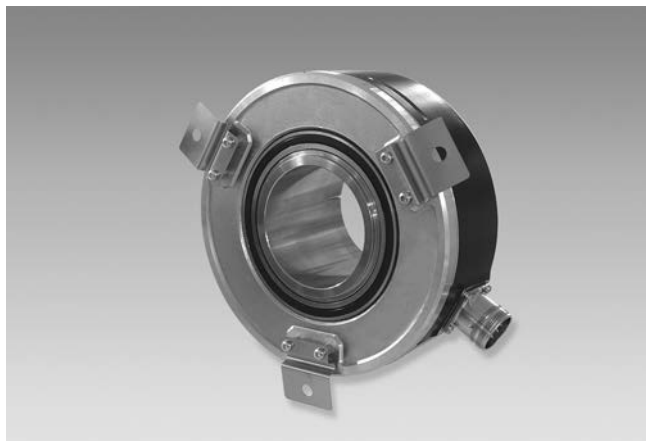

ITD 70 A 4 Y 9 with through hollow shaft

### Features

- Encoder with through hollow shaft max.  $\varnothing 65$  mm
- Max. 2500 pulses per revolution
- Optical sensing method
- Mounting by torque support
- Mounting hole circle  $\varnothing 164$  mm
- TTL or HTL output signals
- Flange connector radial

### Technical data - electrical ratings

Voltage supply	5 VDC $\pm 5$ % 8...30 VDC
Reverse polarity protection	Yes
Consumption w/o load	$\leq 100$ mA
Pulses per revolution	1000...2500
Reference signal	Zero pulse, width $90^\circ$
Sensing method	Optical
Output frequency	$\leq 120$ kHz
Output signals	A, B, N + inverted
Output stages	TTL linedriver (short-circuit proof) HTL push-pull (short-circuit proof)
Interference immunity	DIN EN 61000-6-2
Emitted interference	DIN EN 61000-6-3

### Technical data - mechanical design

Size (flange)	$\varnothing 150$ mm
Shaft type	$\varnothing 40$ ...65 mm (through hollow shaft)
Mounting kit	051
Protection DIN EN 60529	IP 54
Operating speed	$\leq 4000$ rpm
Materials	Housing: aluminium, black, powder-coated Shaft: stainless steel
Operating temperature	$-20$ ... $+70$ °C
Relative humidity	90 % non-condensing
Resistance	DIN EN 60068-2-6 Vibration 10 g, 55-2000 Hz DIN EN 60068-2-27 Shock 100 g, 6 ms
Connection	Connector M23 type 2, 12-pin
Weight approx.	2900 g

Subject to modification in technic and design. Errors and omissions excepted.



**Part number**

ITD 70 A 4 Y 9       **D2SR12** **S**   **IP54** **051**

Mounting kit  
051 Mounting kit 051

Protection  
IP54 IP 54

Through hollow shaft  
40  $\varnothing 40$  mm  
45  $\varnothing 45$  mm  
50  $\varnothing 50$  mm  
55  $\varnothing 55$  mm  
60  $\varnothing 60$  mm  
65  $\varnothing 65$  mm

Operating temperature  
S -20...+70 °C

Connection  
D2SR12 Flange connector type 2, pin contacts, radial, 12-pin

Output signals  
BI A, A inv, B, B inv  
NI A, A inv, B, B inv, 0, 0 inv

Voltage supply / signals  
T 5 VDC / TTL level, linedriver  
H 8...30 VDC / HTL level, push-pull  
R 8...30 VDC / TTL level, linedriver

Pulse number - see table

**Pulse number**

1000 | 1024 | 2048 | 2500

**Accessories**

**Connectors and cables**

11072792	Connector M23 - S2BG12, 1 m cable (incremental)
11072796	Connector M23 - S2BG12, 2 m cable (incremental)
11072804	Connector M23 - S2BG12, 5 m cable (incremental)
11072815	Connector M23 - S2BG12, 10 m cable (incremental)

Subject to modification in technic and design. Errors and omissions excepted.

# Incremental encoders

Through hollow shaft  $\varnothing 40$  to  $\varnothing 65$  mm  
1000...2500 pulses per revolution

## ITD 70 A 4 Y 9

### Output signals

Clockwise rotation when looking at the mounting side.

#### BI-Output signals

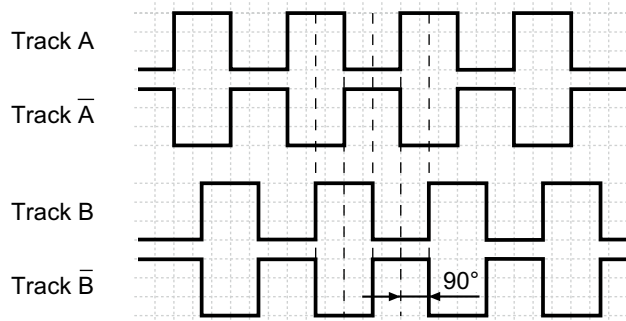

#### NI-Output signals

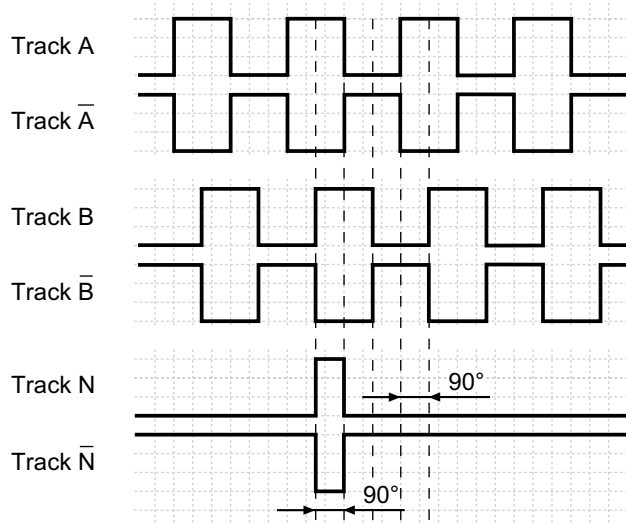

### Terminal assignment

Connector	Assignment
Pin 5	Track A
Pin 6	Track A inv.
Pin 8	Track B
Pin 1	Track B inv.
Pin 3	Track N
Pin 4	Track N inv.
Pin 12	UB
Pin 10	GND
Pin 2	UB-Sense
Pin 11	GND-Sense
Pin 9	–
Pin 7	–

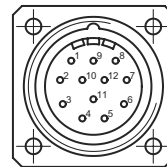

### Trigger level

Outputs	Linedriver
Output level High	$\geq 2.4$ V
Output level Low	$\leq 0.5$ V
Load	$\leq 70$ mA

Outputs	Push-pull short-circuit proof
Output level High	$\geq UB - 3$ V
Output level Low	$\leq 1.5$ V
Load	$\leq 70$ mA



## Dimensions

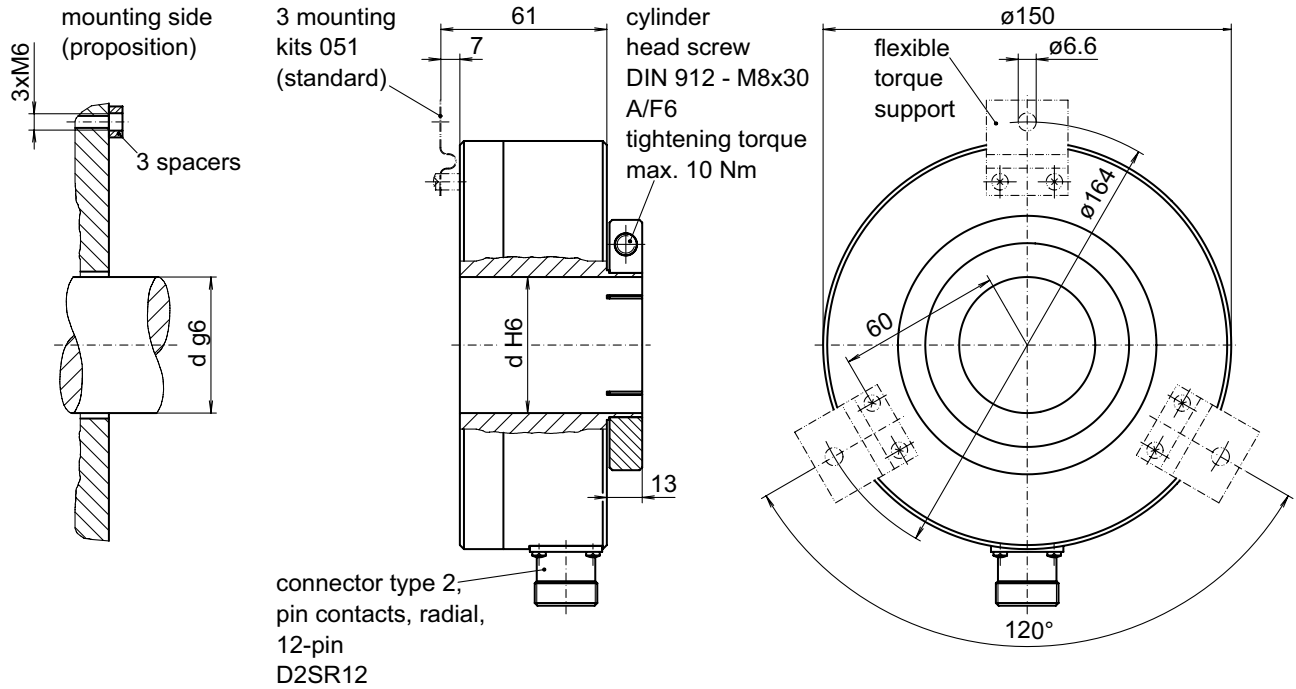

026-40 Y 9