

### Mounting kit 021



#### Features

- Universal mounting option by several pitch diameters.

#### Description

Torque support onto encoder by help of the attached screws. Push encoder onto the drive shaft and mount torque support onto the client side. Fastening clamping ring by the screw provided.

#### Part number

11073119 Torque arm, 1-arm, bolt circle  $\varnothing 65.5 \dots 281$  mm, mounting M4, can be cut to length (mounting kit 021)

#### Scope of delivery

Included:  
torque support, three screws M3 x 6 (DIN 7985 - TX10)

#### Suitable for

ATD2AH00, EIL580 - blind hollow shaft,  
EIL580 - through hollow shaft, EIL580P - blind hollow shaft,  
EIL580P - through hollow shaft, ITD21H00, ITD21H00 HT,  
ITD22H00, ITD22H00 SIL

#### Dimensions

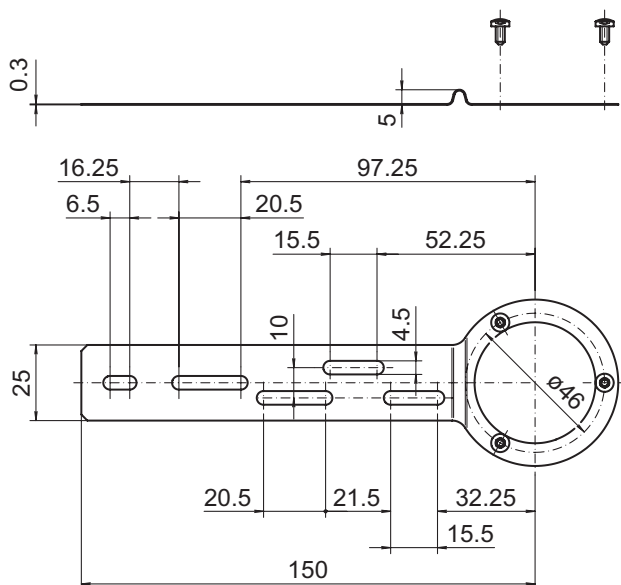

Z00410

#### Assembly drawing

