

Incremental encoders

Through hollow shaft $\varnothing 38$ to $\varnothing 65$ mm
1000...2500 pulses per revolution



RAD ELECTRIC Int.
www.radelectric.co

ITD 70 A 4 Y 2



ITD 70 A 4 Y 2 with through hollow shaft

Features

- Encoder with through hollow shaft max. $\varnothing 65$ mm
- Max. 2500 pulses per revolution
- Optical sensing method
- Mounting by torque support
- Mounting hole circle $\varnothing 164$ mm
- TTL or HTL output signals
- Cable output radial

Optional

- Cable with connector

Technical data - electrical ratings

Voltage supply	5 VDC ± 5 % 8...30 VDC
Reverse polarity protection	Yes
Consumption w/o load	≤ 100 mA
Pulses per revolution	1000...2500
Reference signal	Zero pulse, width 90°
Sensing method	Optical
Output frequency	≤ 120 kHz
Output signals	A, B, N + inverted
Output stages	TTL linedriver (short-circuit proof) HTL push-pull (short-circuit proof)
Interference immunity	DIN EN 61000-6-2
Emitted interference	DIN EN 61000-6-3

Technical data - mechanical design

Size (flange)	$\varnothing 150$ mm
Shaft type	$\varnothing 38$... $\varnothing 65$ mm (through hollow shaft)
Mounting kit	051
Protection DIN EN 60529	IP 54
Operating speed	≤ 4000 rpm
Materials	Aluminium, bare Shaft: stainless steel
Operating temperature	-20 ... $+70$ °C
Relative humidity	90 % non-condensing
Resistance	DIN EN 60068-2-6 Vibration 10 g, 55-2000 Hz DIN EN 60068-2-27 Shock 100 g, 11 ms
Connection	Cable 1 m
Weight approx.	2500 g

Subject to modification in technic and design. Errors and omissions excepted.



Incremental encoders

Through hollow shaft $\varnothing 38$ to $\varnothing 65$ mm
1000...2500 pulses per revolution

RAD ELECTRIC Int.
www.radelectric.co

ITD 70 A 4 Y 2

Part number

ITD 70 A 4 Y 2 **NI** **KR1** **S** **IP54** **051**

Mounting kit
051 Mounting kit 051

Protection
IP54 IP 54

Through hollow shaft
40 $\varnothing 40$ mm
42 $\varnothing 42$ mm
45 $\varnothing 45$ mm
50 $\varnothing 50$ mm
55 $\varnothing 55$ mm
60 $\varnothing 60$ mm
65 $\varnothing 65$ mm

Operating temperature
S -20...+70 °C

Connection
KR1 Cable 1 m, radial

Output signals
NI A, A inv, B, B inv, 0, 0 inv

Voltage supply / signals
T 5 VDC / TTL level, linedriver
H 8...30 VDC / HTL level, push-pull
R 8...30 VDC / TTL level, linedriver

Pulse number - see table

Pulse number

1000	1024	2048	2500
------	------	------	------

Other diameters on request.

Subject to modification in technic and design. Errors and omissions excepted.



Incremental encoders

Through hollow shaft $\varnothing 38$ to $\varnothing 65$ mm
1000...2500 pulses per revolution

ITD 70 A 4 Y 2

Output signals

Clockwise rotation when looking at the mounting side.

NI-Output signals

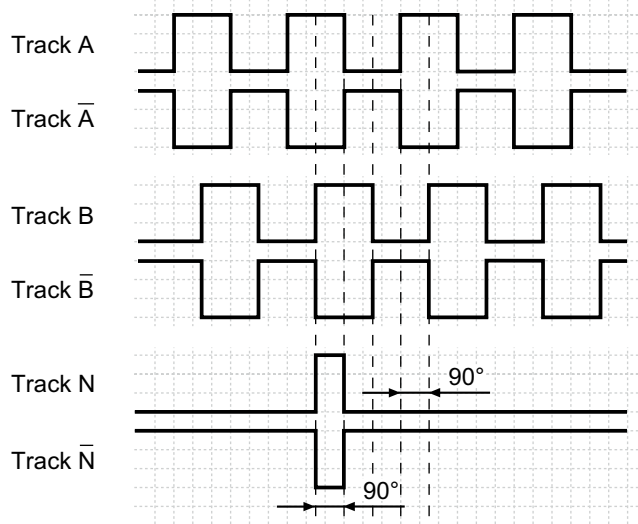

Terminal assignment

Core colour	Assignment
green	Track A
brown	Track A inv.
grey	Track B
black	Track B inv.
pink	Track N
white	Track N inv.
red	UB
blue	GND
yellow	UB-Sense
violet	GND-Sense
transparent	Shield/Housing

Trigger level

Outputs	Linedriver
Output level High	≥ 2.4 V
Output level Low	≤ 0.5 V
Load	≤ 70 mA

Outputs	Push-pull short-circuit proof
Output level High	$\geq UB - 3$ V
Output level Low	≤ 1.5 V
Load	≤ 70 mA



Dimensions

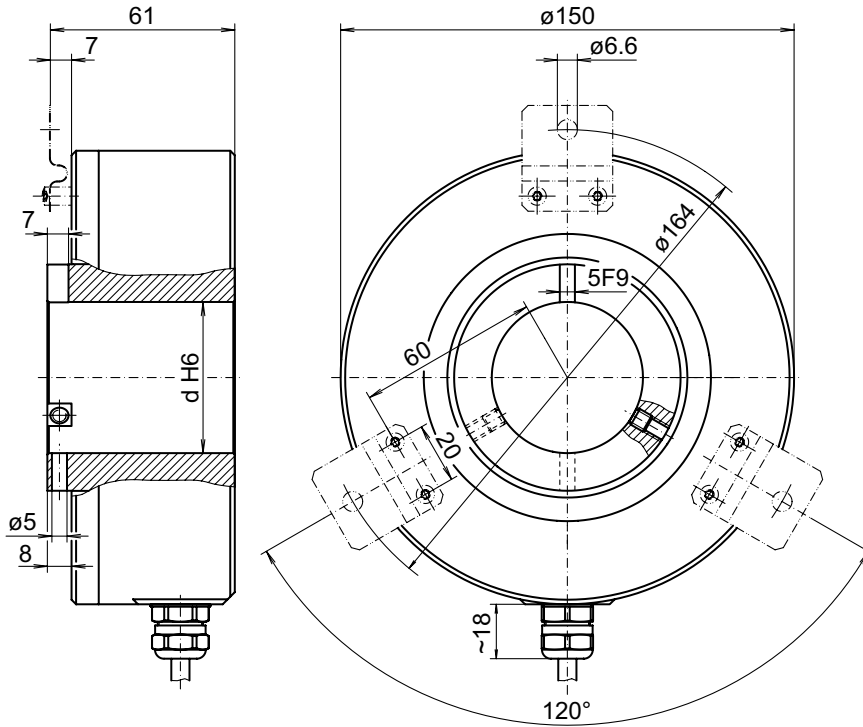

026-40 Y 2